

# USE THIS GUIDE!

This Installation Guide is meant to replace any other guide for models MR-50705 and MR-60705

## Hardware Included

MR-50705 MR-60705

4	6	#8 3/4" phillips pan head screws
2	2	#6 3/8" phillips pan head screws
1	1	Magnetic push latch
1	1	"U channel" strike plate with adhesive backed pad
1	1	Glass door with hinges
12	16	Adjustable shelf pins
2	2	Top and bottom hinges with adhesive pads
0	1	Center hinge with adhesive pad

## Preparation

- 1 Locate the shipping sleeve on the rear of the cabinet. Carefully remove the glass door.
- 2 Cut the shipping strap from the adjustable sleeves and remove.
- 3 Locate the hardware items in the plastic bag.

## Shelf Installation

- 4 Install four shelf pins for each shelf (two on each side, front and rear).
- 5 Slide the shelf in. The shelf's bottom grooves should rest on the shelf pins.

## Door Hardware Installation

- 6 Decide which side of the rack you want the door to open from.
- 7 Using a philips head screwdriver and the 3/4" screws, install the top and bottom hinges in the pilot holes inside the cabinet.
- 8 Install the magnetic push latch on the underside of the top panel using the 3/8" screws.

## Glass Door Installation

- 9 Apply the adhesive backed hinge pads on the outside glass surface. **DO NOT wrap the adhesive pad over the top or side of the glass.**
- 10 Check the hinge's set screw to insure that the rubber tip is intact.
- 11 Slide the glass door into the hinge brackets and tighten set screws. The set screws should be opposite the adhesive pads and on the inside glass surface.
- 12 Make sure the door swings freely and does not hit the cabinet. If it does, loosen the 3/4" screws and adjust the door. The slots in the hinge allow for this adjustment.



Figure 1. Door hardware installation.

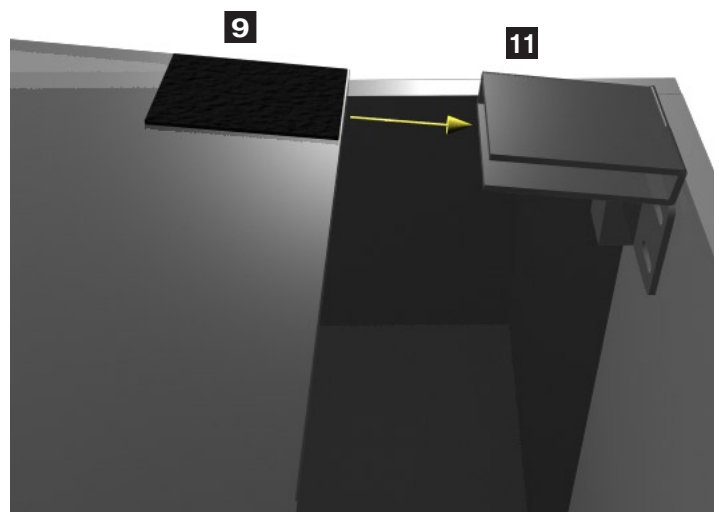
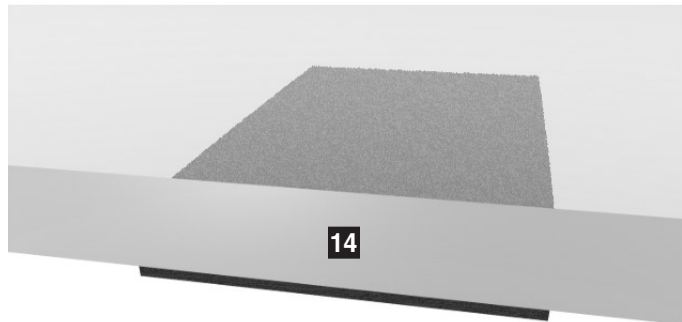

Figure 2. Glass door installation.

**Center Hinge Installation  
 (MR-60705 only)**

- 13** The top of the adhesive pad for the center hinge should be 27 1/8" from the top of the glass door.
- 14** Apply the adhesive backed hinge pads on the outside glass surface. **DO NOT** wrap the adhesive pad over the top or side of the glass.
- 15** Check the hinge's set screw to insure that the rubber tip is intact. This will insure that the glass does not slip out of the hinge with use. If it is not intact, please contact your dealer.
- 16** Locate and align hinge with mounting holes on inside of cabinet. Slide the hinge onto the glass door with the set screw against the inside glass surface. Tighten the set screw with a flat head screwdriver. Screw hinge to cabinet.



**Figure 2.** Adhesive pad applied to the outside glass surface.

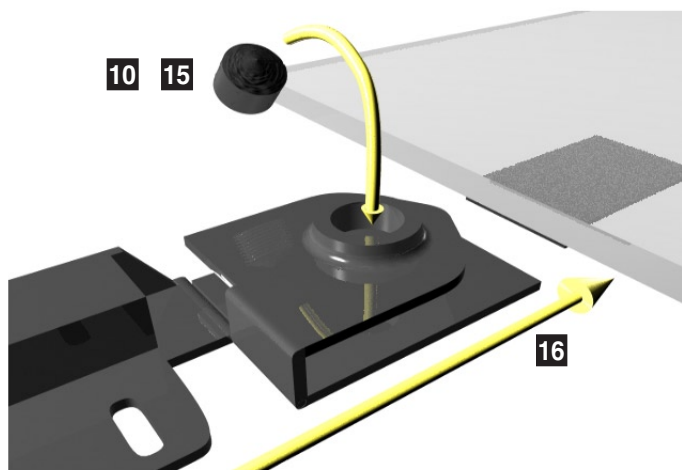

**Figure 3.** Center hinge installation.

**Strike Plate Installation**

- 17** At the opposite end from the hinges, attach the adhesive backed strike plate pad to the top corner of the glass door.
- 18** Slide the "U channel" strike plate over the pad. This should be aligned with the magnetic push latch when the door is closed.

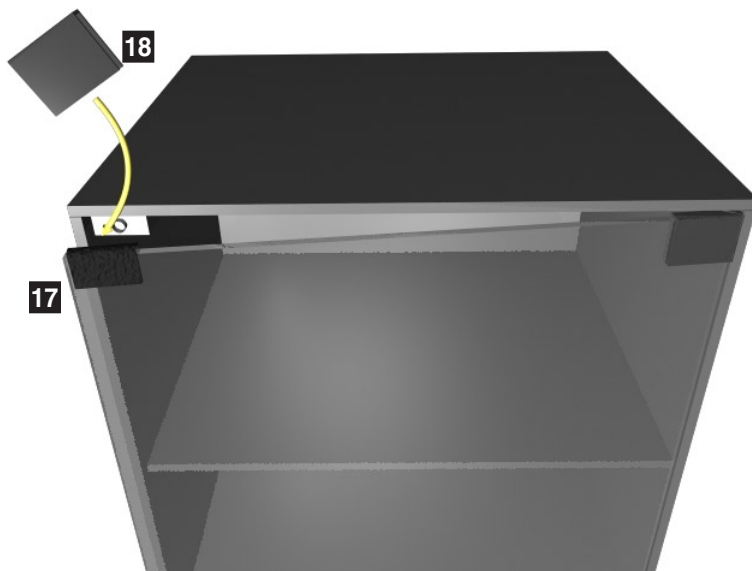

**Figure 4.** Strike plate installation.

**IMPORTANT**

→ When installing, adjusting, or reinstalling hinges, please check the hinge set screw to insure that the rubber tip is intact. This will insure that the glass does not slip out of the hinge with use. If it is not intact, please contact your dealer.